

COMPAX R – Screw Compactor

High-Performance Lightweight Reject Dewatering Solution

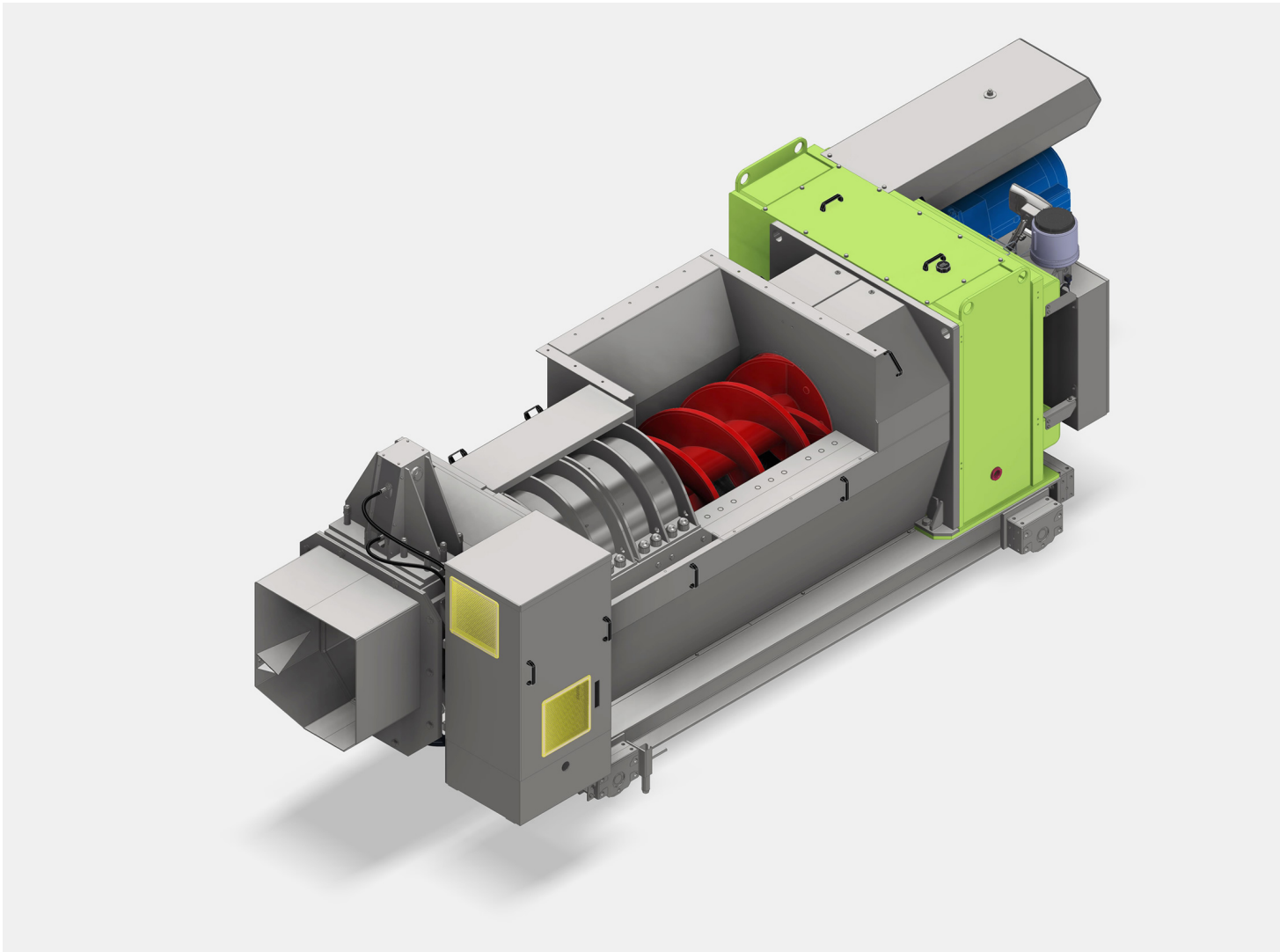

COMPAX R – SCREW COMPACTOR

High-Performance Lightweight Reject Dewatering Solution

Technology

The Compax R is a sturdy high-performance screw press designed to dewater lightweight coarse rejects, reducing handling, transport and disposal costs for paper. Utilizing a slow-speed, high-torque screw, the reject gets first dewatered by means of gravity, and then pressed against the press nozzle flap. The high-pressure single flap hydraulic cylinder regulates the counter-pressure, maintaining dewatering and high dryness in all operating conditions. A high-performance fast micro controller optimizes operation with varying throughputs, by keeping constant torque and variable screw speed minimizing wear and low maintenance.

Features

- The fast micro controller adjusts screw speed, torque, and press flap angle for optimized dryness up to 70%.
- High throughput capacity up to 50 BDMT/day Sturdy SEW gearmotor ensures high torque and durable performance.
- Wear-resistant components with fast slide-in/out installation for minimal downtime.
- Designed for 24/7 operation with low maintenance and easy accessible components
- Refurbishment programs for screws, screens, and other wear parts, ensuring long-term sustainability.

Why to buy

- High return on investment through highest final discharge dryness
- Low OPEX due to efficient and reliable performance.
- Minimal downtime with fast and easy maintenance access through slide in / out.
- High availability for 24/7 operation, achieving up to 10,000 continuous hours.
- Sustainable design with refurbishable components
- Industry-leading performance with over 500 proven installations worldwide.

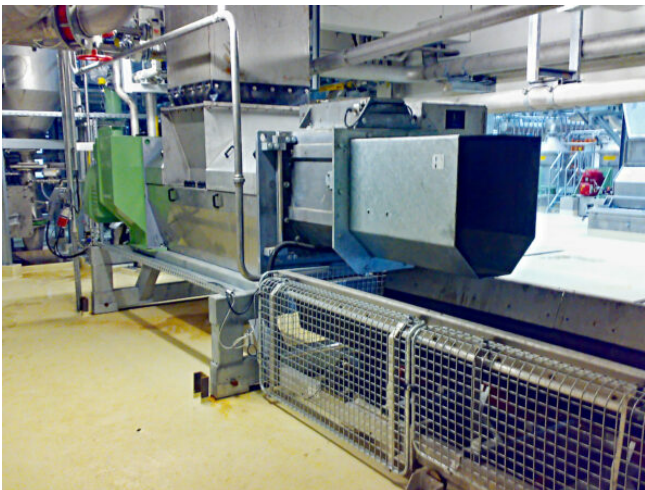

Typical & Proven Process

- Dewatering and Pressing Lightweight Reject from Pulping.
- Pressing “Pre- Treated” Lightweight Reject from Drum Pulper.
- Pressing Lightweight Reject from De-Trashing / Sorting Drum.
- Dewatering and Pressing Lightweight Reject from Hole Screening.

See the following Products as well

- COMPAX CFX 80R.
- COMPAX CFX- F 50, 60 for Fibrous Residual Material
- ECOMPAX ECX
- MBX- Belt Conveyors and MCS- Container Stations a.m.mm
- RSP Sludgeand Fiber Residual Screw Press RSP 1150,800, and 650
- Reject Pre-Dewatering with ELEPHANT Disk Thickener

Specifications

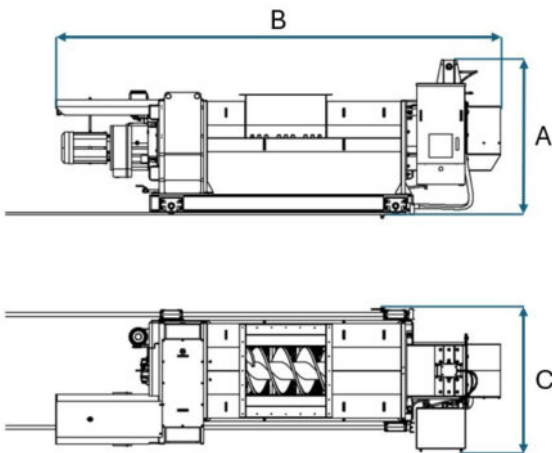

| | CFX 50R | CFX 60R |
|---------------------|-----------|---------|
| Screw diameter [mm] | 500 | 600 |
| Height (A) [mm] | 1680 | 1940 |
| Length (B) [mm] | 4690 | 5560 |
| Width (C) [mm] | 1730 | 1910 |
| Power [kW] | 22 | 30 |
| Dryness | Up to 70% | |



Meri Environmental Solutions GmbH

Bodenseestr. 113
81243 Munich, Germany
Tel. +49 89 59 33 44
info@meri.de

Voith Meri Environmental Solutions, Inc.

2620 E. Glendale Avenue
P.O. Box 1262
Appleton WI 54911-1262, USA
Tel. +1 920 734-8485
info@meriusa.com

Meri Sistemas e Tecnologia Ltda.

R. Friedrich von Voith, 825
São Paulo – SP – 02995-000, Brasil
Tel. +55 11 3944-6644
meribrasil@meribrasil.com.br

**Meri Environmental Technology
(Kunshan) Co., Ltd.**

Room 203, No.5, Qinghua Tuspark
Zuchongzhi Road 1666
Kunshan, Jiangsu PRC, China
Tel. +86 51 28 68 90 834
info@meri.cn

www.meri.de



Note: All product-related data and information in this publication shall serve for information purposes only. They shall not be interpreted or intended to represent any kind of warranty or guarantee. The only legally binding statements are those contained solely within our quotations. Errors and omissions excepted. Technical data are subject to change.