

# MMH-WCMA – Meri Material Handling Wire Cutter

The Automatic Wire Cutter (WCMA) is used to automatically cut binding wires from baled material while the feed conveyor remains in operation

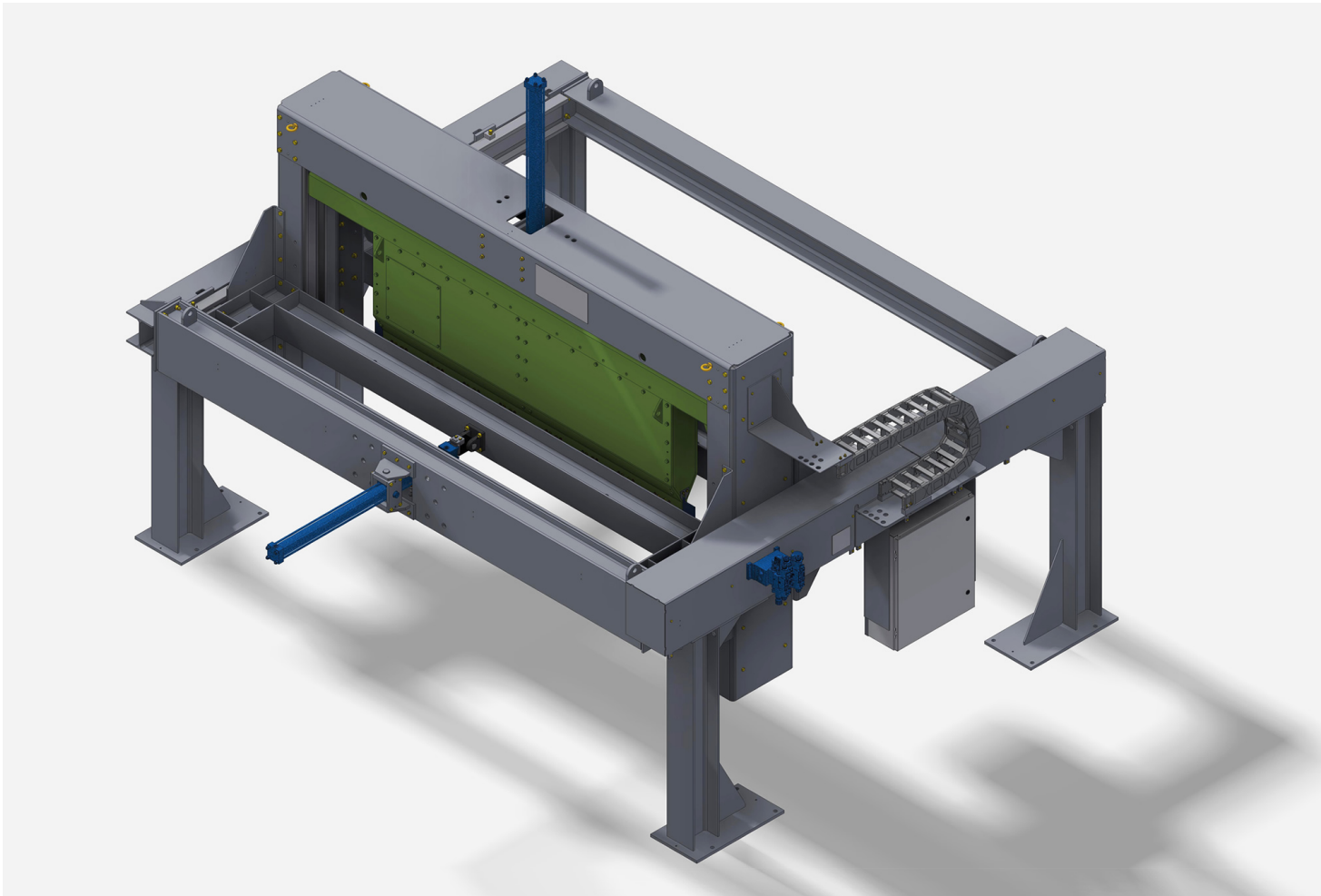

# MMH-WCMA – Meri Material Handling Wire Cutter

The Automatic Wire Cutter (WCMA) is used to automatically cut binding wires from baled material while the feed conveyor remains in operation

## Technology

The WCMA is used to cut the binding wires on the bales.

The WCMA is designed to primarily be used continuous low consistency pulper applications. The WCMA automatically cuts the binding wires from the baled material without stopping the conveyor. Thus, the WCMA can operate continuously without interruption.

## Features

- Safe reliable cutting
- Reduced cost for manpower
- High uptime
- Long service life
- Easy to service and maintain

## Why to buy

- Removes operator interaction with wire cutting and removal from baled material
- The Wire Cutting machine can be integrated into existing system configurations
- Reciprocating knife design yields reliable cutting without the downward force generated by a standard guillotine style cutter
- Minimized commissioning time on site due to workshop testing
- All functional components are completely pre-assembled for easy on-site installation.



# Typical & Proven Process Applications

Recycled Bale wire cutting Applications:

- Paper
- Textile
- Plastics
- Metal
- Agricultural
- Foam

## See the following Products as well

- MMH-DLAT
- MMH-DTOP - Meri Material Handling Automatic De-wiring Machine
- MMH-FC - Meri Material Handling Feed Conveyor
- MMH-DMOB - Meri Material Handling Mobile De-wiring

## Specifications

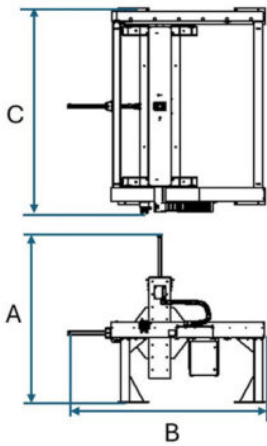

		MMH-WCMA T 2000	MMH-WCMA T 2500	MMH-WCMA T 2800
Height (A)	[mm]	3728	3728	3728
Length (B)	[mm]	4379	4379	4379
Width (C)	[mm]	4062	4562	4862
Power	[kW]	18	18	18
Options		Incline version upon request		



**Meri Environmental Solutions GmbH**

Bodenseestr. 113  
81243 Munich, Germany  
Tel. +49 89 59 33 44  
info@meri.de

**Voith Meri Environmental Solutions, Inc.**

2620 E. Glendale Avenue  
P.O. Box 1262  
Appleton WI 54911-1262, USA  
Tel. +1 920 734-8485  
info@meriusa.com

**Meri Sistemas e Tecnologia Ltda.**

R. Friedrich von Voith, 825  
São Paulo – SP – 02995-000, Brasil  
Tel. +55 11 3944-6644  
meribrasil@meribrasil.com.br

**Meri Environmental Technology  
(Kunshan) Co.,Ltd.**

Room 203, No.5, Qinghua Tuspark  
Zuchongzhi Road 1666  
Kunshan, Jiangsu PRC, China  
Tel. +86 51 28 68 90 834  
info@meri.cn

[www.meri.de](http://www.meri.de)



**Note:** All product-related data and information in this publication shall serve for information purposes only. They shall not be interpreted or intended to represent any kind of warranty or guarantee. The only legally binding statements are those contained solely within our quotations. Errors and omissions excepted. Technical data are subject to change.